

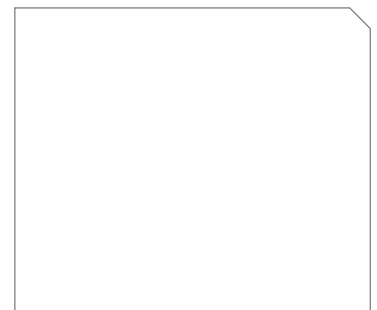

CAPITULO 4

CHAVETAS

CHAVETAS

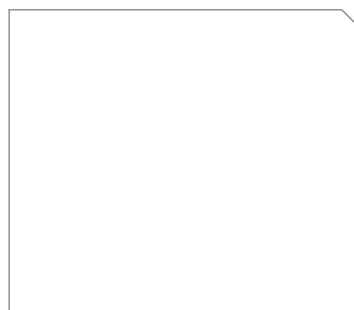
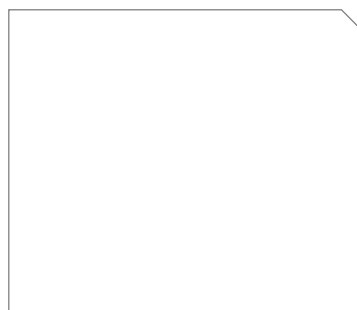
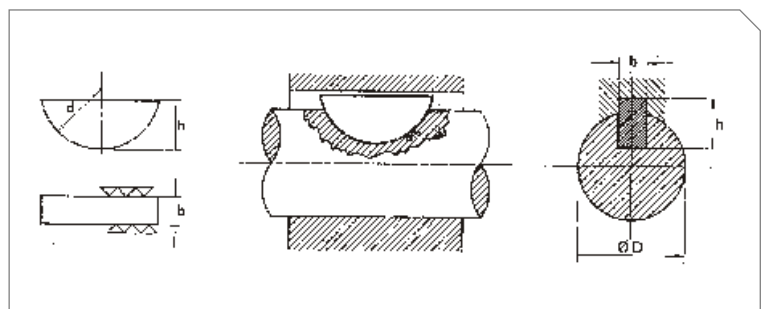
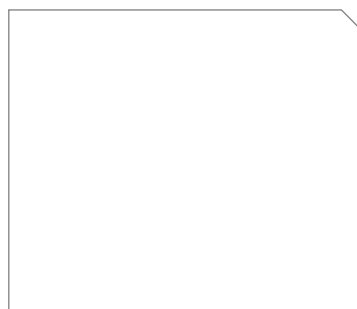
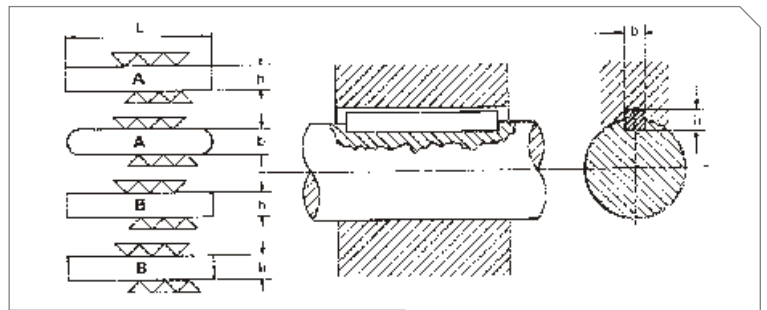
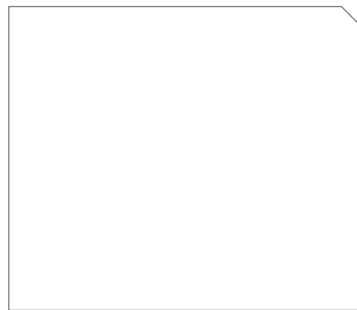
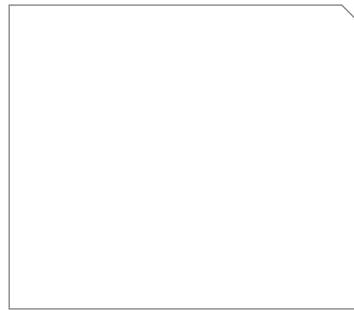

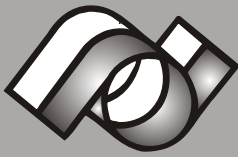

CHAVETAS Planas

Capítulo 4

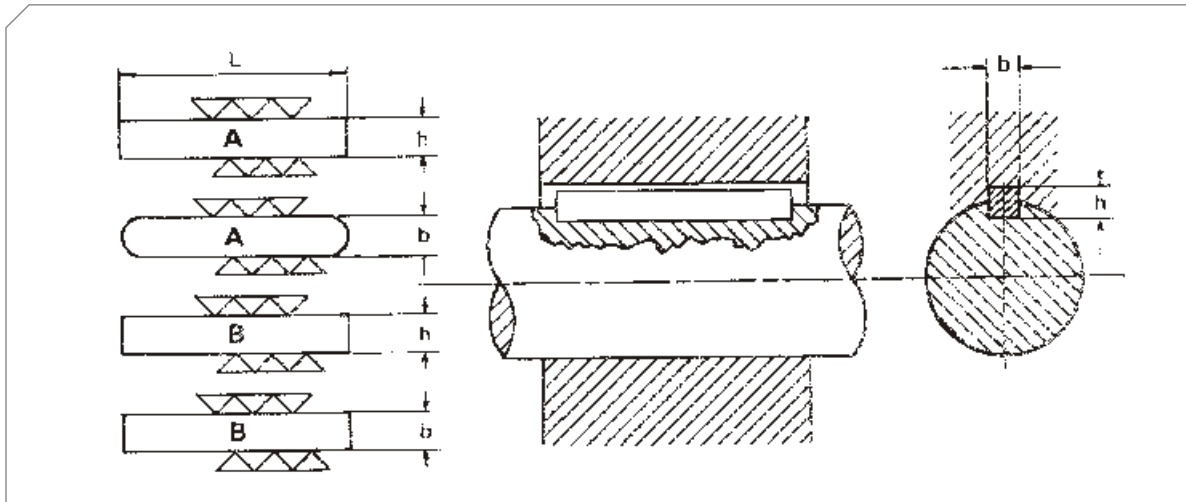

SECCION DE LA CHAVETA	ANCHO b	4	5	6	8	10	12	14	16	18	*20	22	25	28	32	36	40	
	TOLERANCIA	-0,03			-0,036				-0,043									
	ALTURA h	4	5	6	7	8	8	9	10	11	*12	14	14	16	18	20	22	
	TOLERANCIA	-0,03			-0,09													
PARA Ø DE EJE	MAYOR	10	12	17	22	30	38	44	50	58	65	75	85	95	110	130	150	
	HASTA	12	17	22	30	38	44	50	58	65	75	85	95	110	130	150	170	

TOLERANCIA EN EL LARGO: HASTA 28 mm: -0,2 mm
 HASTA 29 mm HASTA 80 mm: -0,3 mm
 DESDE 81 mm EN ADELANTE: -0,5 mm

* IDENTIFICACION: DIN-6885 A-20x12x125

Ej.: TIPO A / ANCHO b = 20 mm / ALTURA h = 12 mm / LARGO L = 125 mm

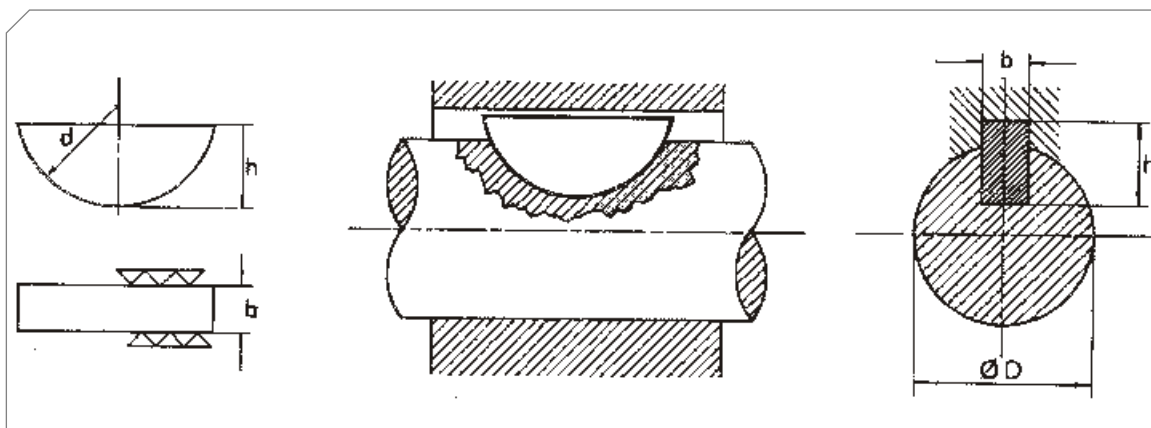
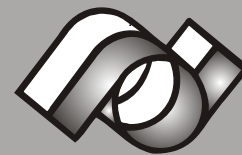

SECCION DE LA CHAVETA	ANCHO b	2	2,5	3	3	3	4	4	4	5	5	5	6	*6	6	6	8	8	8	10	10	10
	TOLERANCIA	-0,03		-0,03			-0,03			-0,03			-0,03			-0,03			-0,03			-0,03
	ALTURA h	3,7	3,7	3,7	5	6,5	5	6,5	7,5	6,5	7,5	9	7,5	*9	10	11	9	11	13	11	13	16
	TOLERANCIA	-0,1	-	-	-	-	-	-	-	-	-	-	-	-	-0,2	-	-0,1	-0,2	-	-	-	-
PARA USAR EN Ø DE EJE	DIAMETRO d	10	10	10	13	16	13	16	19	16	19	22	19	*22	25	28	22	28	32	28	32	45
	TOLERANCIA	-0,1		-0,1			-0,1			-0,1			-0,2		-0,1		-0,2					
	MAYOR	6		8			10			12			17		22		30					
	HASTA	8		10			12			17			22		30		38					

* IDENTIFICACION: DIN-6888-6x9 Ø 22 Ej.: ANCHO b = 6mm./ALTURA h = 9mm./DIAMETRO d = 22mm.

DIMENSIONES EN MM.

